



---

# Hybrid Quantum Computers with superconducting circuits & atomic ensembles

**David Petrosyan**

IESL-FORTH, Greece

# Hybrid Quantum Processor

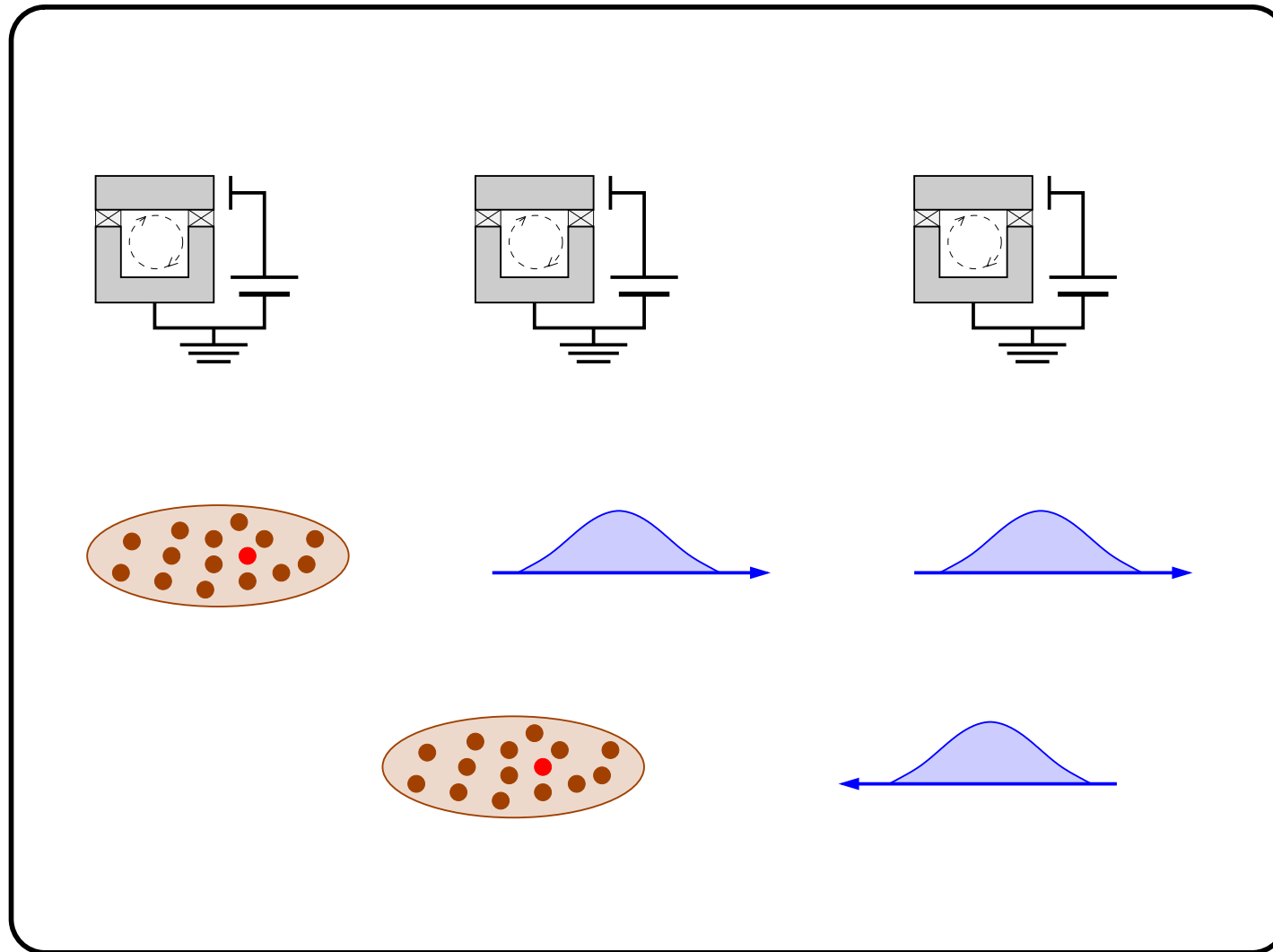

# Hybrid Quantum Processor

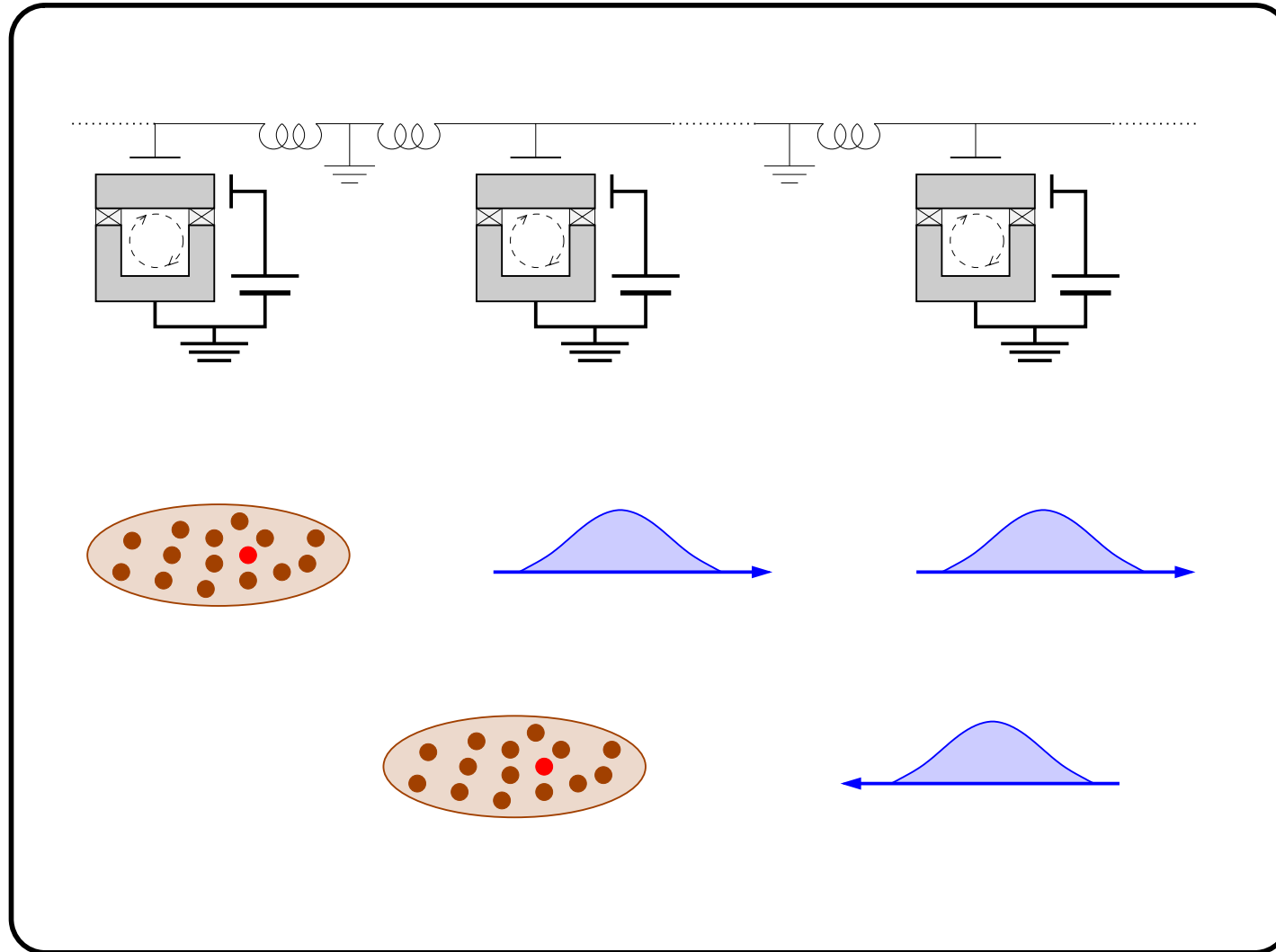

# Hybrid Quantum Processor

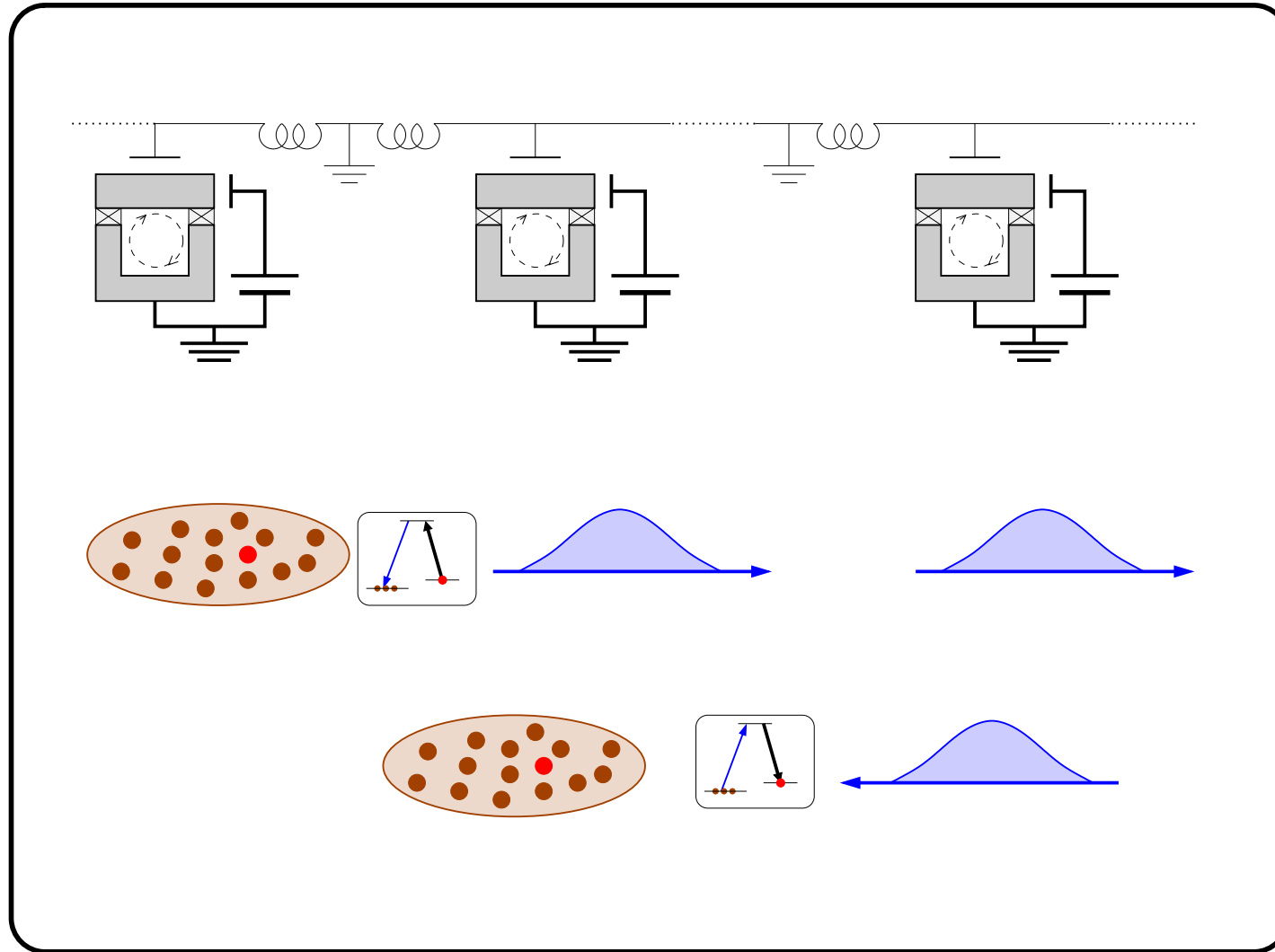

# Hybrid Quantum Processor

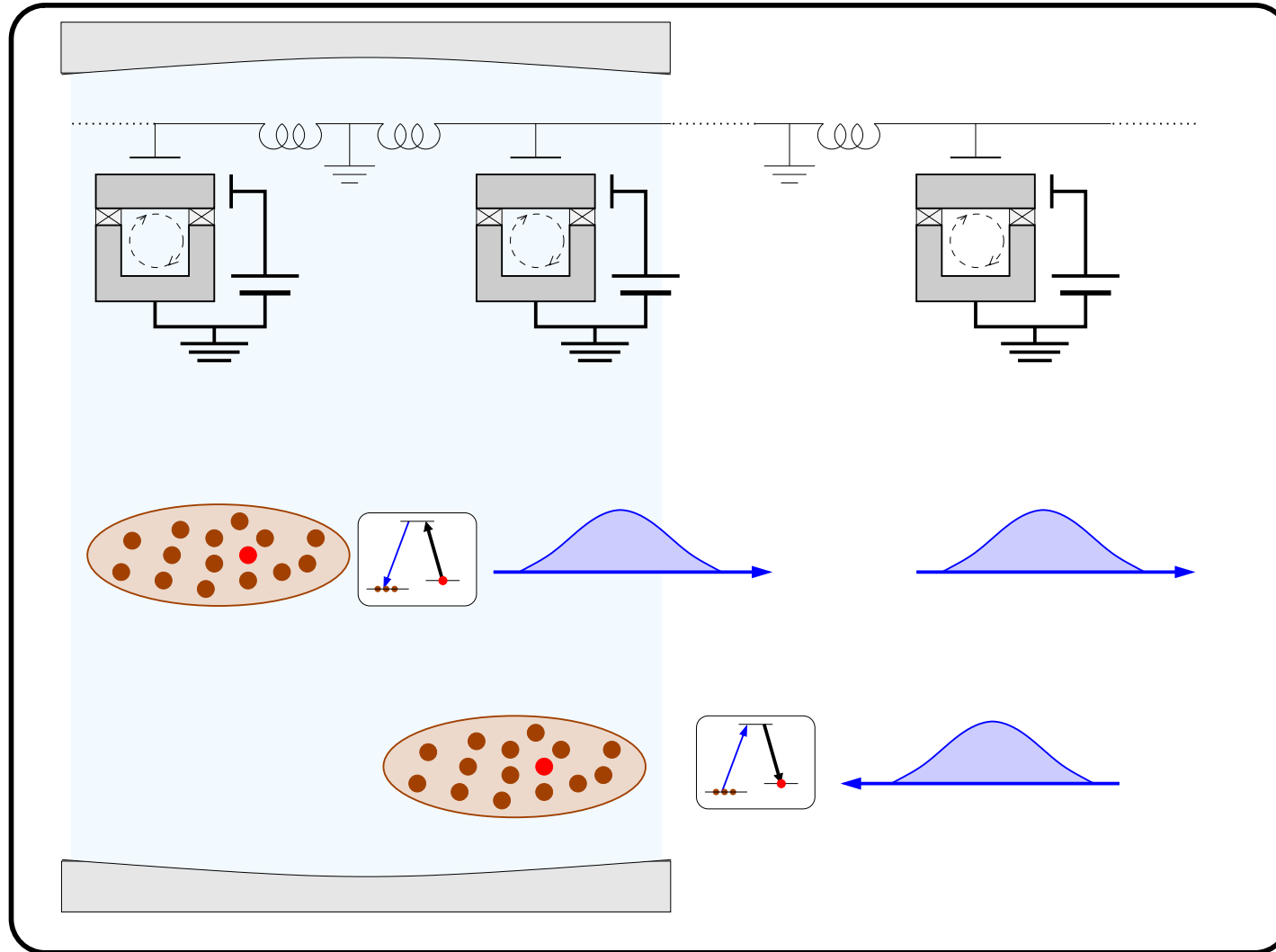

# Hybrid Quantum Processor

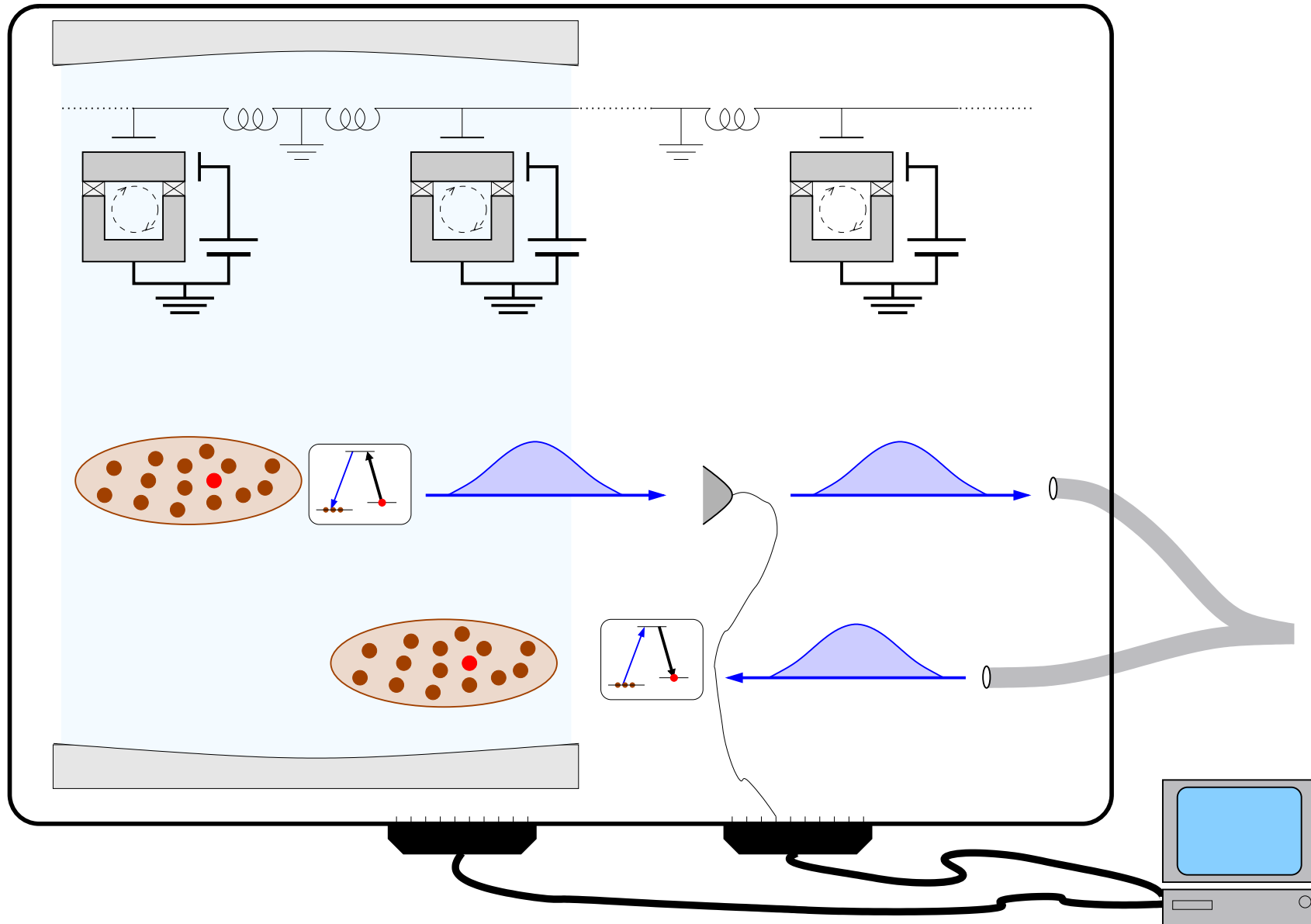

# Outline

---



- Photonic Qubit

# Outline

---



- Photonic Qubit
- Atomic Ensemble Qubit

# Outline

---



- Photonic Qubit
- Atomic Ensemble Qubit
- Superconducting Charge Qubit

# Outline

---



- Photonic Qubit
- Atomic Ensemble Qubit
- Superconducting Charge Qubit
- Microwave Coplanar Waveguide Resonator as Quantum Bus
  - *Coupling SC qubits*
  - *State transfer between SC and AE qubits*

- Photonic Qubit
- Atomic Ensemble Qubit
- Superconducting Charge Qubit
  
- Microwave Coplanar Waveguide Resonator as Quantum Bus
  - *Coupling SC qubits*
  - *State transfer between SC and AE qubits*
  
- Atoms in CPW Resonator
  - *Intracavity resonant dipole-dipole interaction*
  - *Van der Waals interaction*
  - *Applications: Interface of SPh and AE qubits*

- Photonic Qubit
- Atomic Ensemble Qubit
- Superconducting Charge Qubit
  
- Microwave Coplanar Waveguide Resonator as Quantum Bus
  - *Coupling SC qubits*
  - *State transfer between SC and AE qubits*
  
- Atoms in CPW Resonator
  - *Intracavity resonant dipole-dipole interaction*
  - *Van der Waals interaction*
  - *Applications: Interface of SPh and AE qubits*
  
- Conclusions

# Photonic Qubit

---



Single-photon wavepacket in the polarization state

$$|\psi\rangle = \alpha |V\rangle + \beta |H\rangle \quad \text{with} \quad |\alpha|^2 + |\beta|^2 = 1$$

$|V\rangle \equiv |0\rangle$  &  $|H\rangle \equiv |1\rangle$  form the computational basis  $\{|0\rangle, |1\rangle\}$

# Photonic Qubit

Single-photon wavepacket in the polarization state

$$|\psi\rangle = \alpha |V\rangle + \beta |H\rangle \quad \text{with} \quad |\alpha|^2 + |\beta|^2 = 1$$

$|V\rangle \equiv |0\rangle$  &  $|H\rangle \equiv |1\rangle$  form the computational basis  $\{|0\rangle, |1\rangle\}$

Single-rail  $\leftrightarrow$  Dual-rail conversion

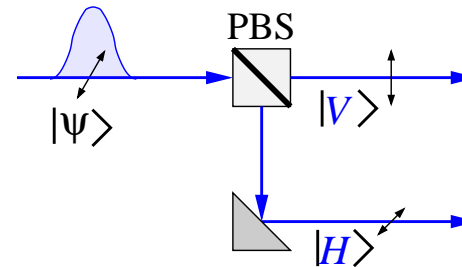

# Photonic Qubit

Single-photon wavepacket in the polarization state

$$|\psi\rangle = \alpha |V\rangle + \beta |H\rangle \quad \text{with} \quad |\alpha|^2 + |\beta|^2 = 1$$

$|V\rangle \equiv |0\rangle$  &  $|H\rangle \equiv |1\rangle$  form the computational basis  $\{|0\rangle, |1\rangle\}$

Single-rail  $\leftrightarrow$  Dual-rail conversion

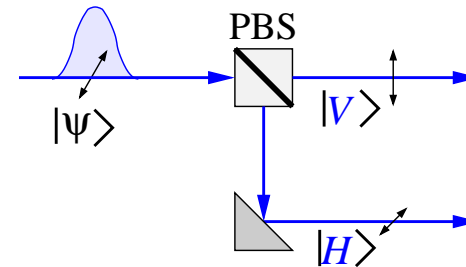

Single-qubit unitary transformations  $U \propto R(\vartheta) \otimes T(\phi)$  can be implemented with linear-optics operations

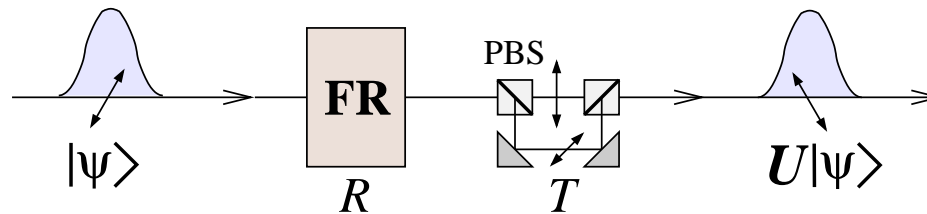

# Atomic Ensemble Qubit



$$|\psi\rangle = \alpha |s^{(0)}\rangle + \beta |s^{(1)}\rangle$$

with collective atomic states

$$|s^{(0)}\rangle \equiv |g_1, g_2, \dots, g_N\rangle$$

$$|s^{(1)}\rangle \equiv \frac{1}{\sqrt{N}} \sum_{j=1}^N e^{i\phi(z_j)} |g_1, \dots, s_j, \dots, g_N\rangle$$

Very long lifetime  $1/\gamma_{sg} \gtrsim 1 \text{ ms}$

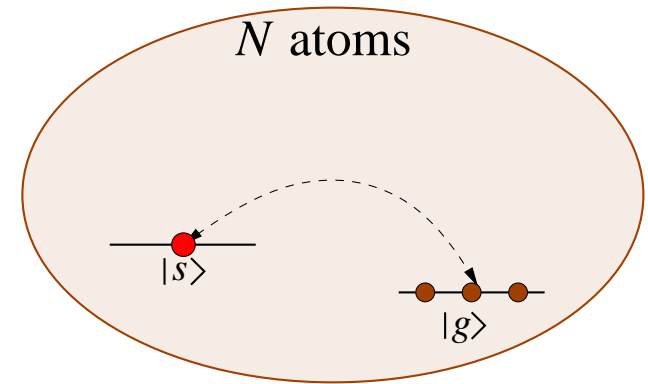

# Atomic Ensemble Qubit



$$|\psi\rangle = \alpha |s^{(0)}\rangle + \beta |s^{(1)}\rangle$$

with collective atomic states

$$|s^{(0)}\rangle \equiv |g_1, g_2, \dots, g_N\rangle$$

$$|s^{(1)}\rangle \equiv \frac{1}{\sqrt{N}} \sum_{j=1}^N e^{i\phi(z_j)} |g_1, \dots, s_j, \dots, g_N\rangle$$

Very long lifetime  $1/\gamma_{sg} \gtrsim 1$  ms

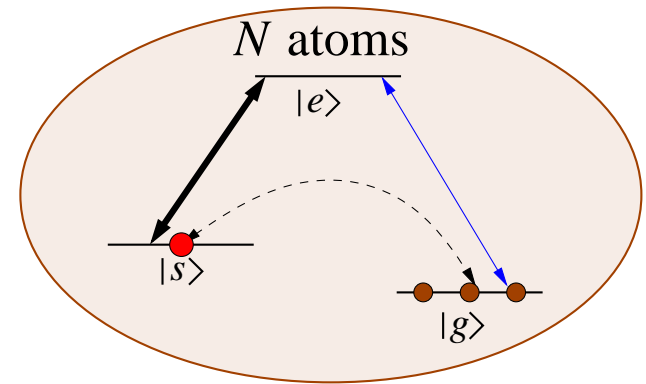

- $|s^{(1)}\rangle$  symmetric single excitation (spin-flip) state equivalent to EIT stored single photon

⇒ Interconnect AE Qubit and SPh Qubit via EIT

# Superconducting Charge Qubit



## Cooper-pair box Hamiltonian

$$H = 4E_C \sum_n (n - \bar{n})^2 - E_J \cos(\pi\Phi/\Phi_0) \sum_n (|n\rangle\langle n+1| + \text{H.c.})$$

$E_C = e^2/2C_{\text{tot}}$  – charging energy

$\bar{n} = CV/2e$  – injected polarization charge

$E_J$  – Josephson tunneling energy ( $E_J/\hbar \sim 10$  GHz)

$\Phi = AB_{\perp}$  – external magnetic flux ( $\Phi_0 = hc/2e$  flux quantum)

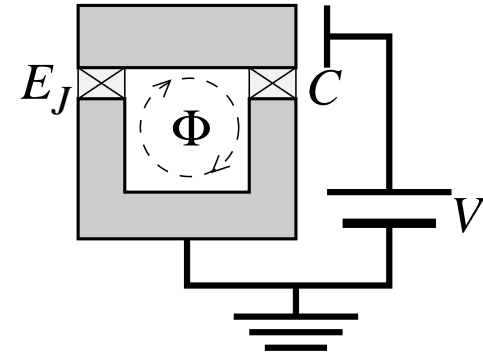

# Superconducting Charge Qubit



## Cooper-pair box Hamiltonian

$$H = 4E_C \sum_n (n - \bar{n})^2 - E_J \cos(\pi\Phi/\Phi_0) \sum_n (|n\rangle\langle n+1| + \text{H.c.})$$

$E_C = e^2/2C_{\text{tot}}$  – charging energy

$\bar{n} = CV/2e$  – injected polarization charge

$E_J$  – Josephson tunneling energy ( $E_J/\hbar \sim 10$  GHz)

$\Phi = AB_{\perp}$  – external magnetic flux ( $\Phi_0 = hc/2e$  flux quantum)

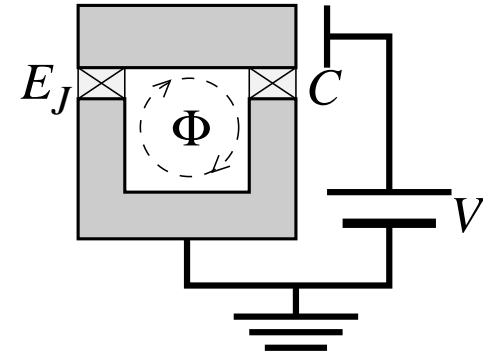

- For  $E_C \gg E_J$  and charge degeneracy point  $\bar{n} = \frac{1}{2} \Rightarrow$  TLS

$$|0\rangle = \frac{1}{\sqrt{2}}(|0\rangle - |1\rangle) \quad |1\rangle = \frac{1}{\sqrt{2}}(|0\rangle + |1\rangle)$$

with  $\hbar\omega_{10} = 2E_J \cos(\pi\Phi/\Phi_0)$  tunable by  $B_{\perp}$

# Superconducting Charge Qubit



## Cooper-pair box Hamiltonian

$$H = 4E_C \sum_n (n - \bar{n})^2 - E_J \cos(\pi\Phi/\Phi_0) \sum_n (|n\rangle\langle n+1| + \text{H.c.})$$

$E_C = e^2/2C_{\text{tot}}$  – charging energy

$\bar{n} = CV/2e$  – injected polarization charge

$E_J$  – Josephson tunneling energy ( $E_J/\hbar \sim 10$  GHz)

$\Phi = AB_{\perp}$  – external magnetic flux ( $\Phi_0 = hc/2e$  flux quantum)

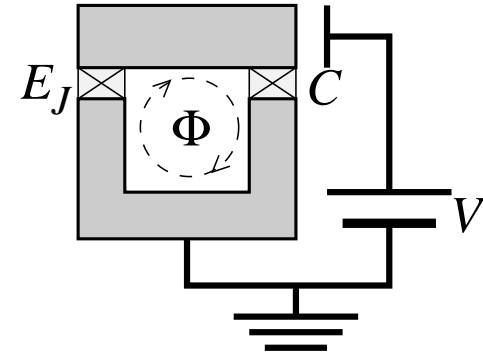

- For  $E_C \gg E_J$  and charge degeneracy point  $\bar{n} = \frac{1}{2} \Rightarrow$  TLS

$$|0\rangle = \frac{1}{\sqrt{2}}(|0\rangle - |1\rangle) \quad |1\rangle = \frac{1}{\sqrt{2}}(|0\rangle + |1\rangle)$$

with  $\hbar\omega_{10} = 2E_J \cos(\pi\Phi/\Phi_0)$  tunable by  $B_{\perp}$

Single-qubit rotations implemented with resonant MW fields ( $\varphi_{01} \sim 10^4 a_0 e$ )

**But**  $1/\gamma_q \gtrsim 1 \mu\text{s} \Rightarrow$  fast qubit decoherence

# Coupling SC Qubits via CPW resonator

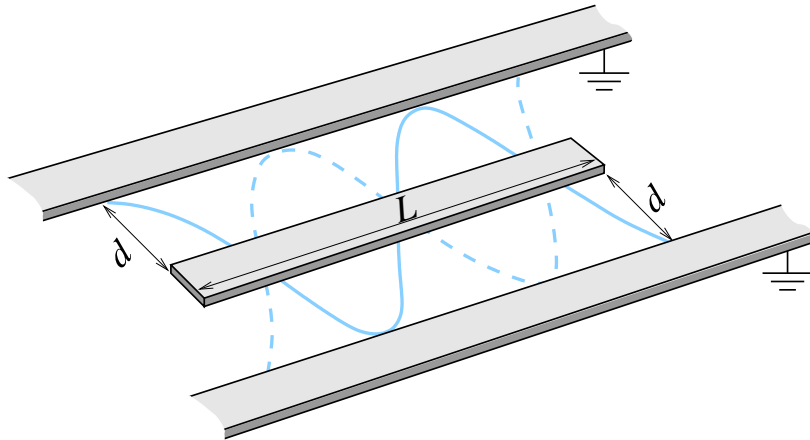

Strip-line length  $L \simeq 1$  cm and electrode distance  $d \sim 10 \mu\text{m}$

$u(\mathbf{r}) = e^{-r_{\perp}/d} \cos(m\pi z/L)$  or  $\sin(m\pi z/L)$  cavity mode function  
with  $m$  even or odd integer and  $z \in [-L/2, L/2]$ .

$m = 1 - 5$  ( $m + 1$  field antinodes)

$\lambda_c = \frac{2L}{m} \simeq 4 - 20$  mm and  $\omega_c/2\pi = \frac{c}{\lambda_c \sqrt{\epsilon_r}} \simeq 6 - 30$  GHz

$\epsilon_c = \sqrt{\frac{\hbar\omega_c}{\epsilon_0\pi d^2 L}} \simeq 2 - 5$  mV cm<sup>-1</sup> field per photon in the cavity

$Q \simeq 10^5 - 10^6 \Rightarrow$  photon decay rate  $\kappa = \frac{\omega_c}{Q} \simeq 10^4 - 10^5$  Hz

# Coupling SC Qubits via CPW resonator

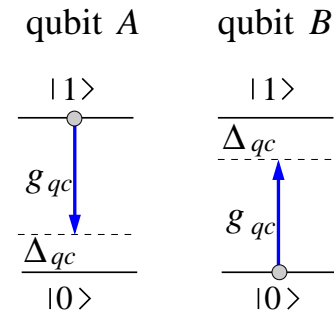
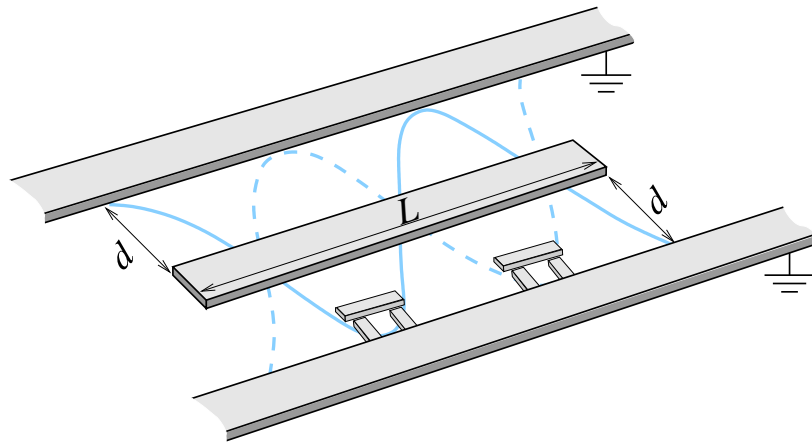

$g_{qc} = \frac{\omega_{01}}{\hbar} \epsilon_c \simeq 2\pi \times 50$  MHz qubit–cavity coupling rate;  $\Delta_{qc} = \omega_{10} - \omega_c$  detuning

# Coupling SC Qubits via CPW resonator

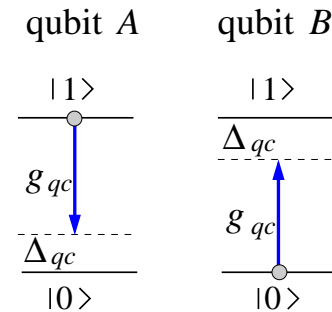
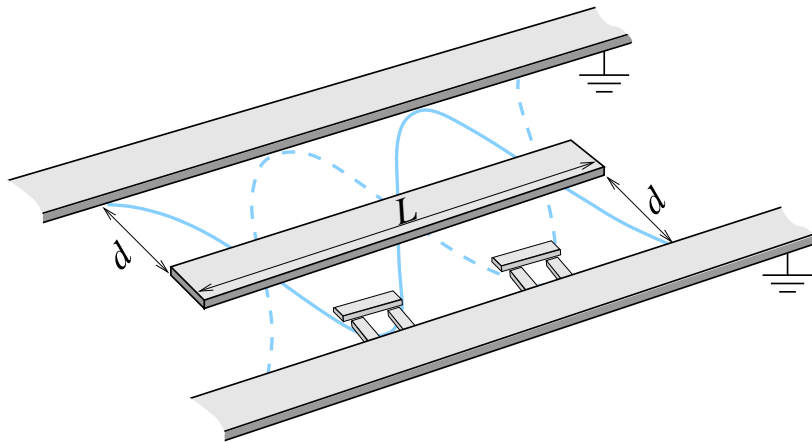

$g_{qc} = \frac{\omega_{01}}{\hbar} \epsilon_c \simeq 2\pi \times 50$  MHz qubit–cavity coupling rate;  $\Delta_{qc} = \omega_{10} - \omega_c$  detuning

$\Delta_{qc}^A = \Delta_{qc}^B \gg g_{qc} \Rightarrow$  **Effective Hamiltonian** (2nd-order in  $g_{qc}$ ):

$$V_{AB}^{(2)} = \hbar G_{AB} (\hat{\sigma}_+^A \hat{\sigma}_-^B + \hat{\sigma}_+^B \hat{\sigma}_-^A) \quad \text{with } G_{AB} = \frac{g_{qc}^2}{\Delta_{qc}} - \text{Exchange constant}$$

SWAP or  $\sqrt{\text{SWAP}}$  entangling operations

# State Transfer between SC & AE Qubits

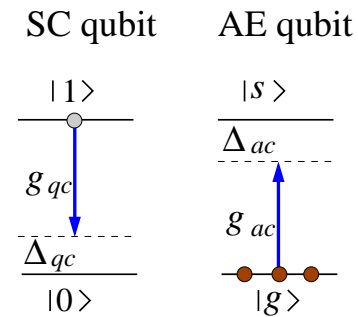
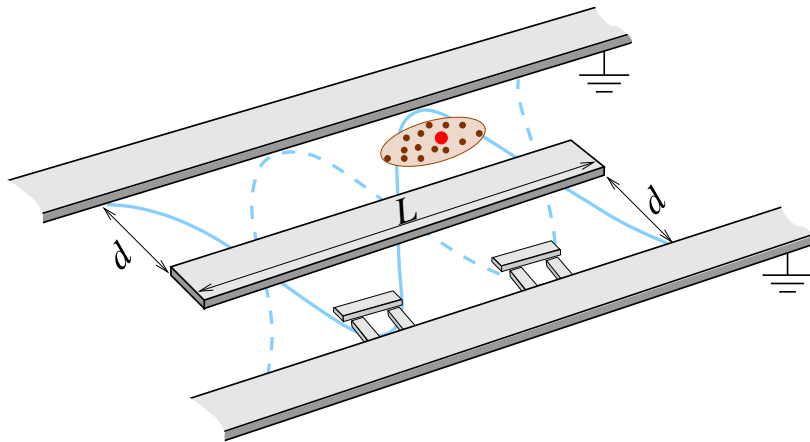

$$N = \rho_a V_a \sim 10^6 \text{ atoms at } \rho_a \sim 4 \times 10^{13} \text{ cm}^{-3} \text{ \& } V_a \sim d/2 \times d/2 \times \lambda_c/10$$

$|g\rangle \leftrightarrow |s\rangle$  – hyperfine transition ( $\omega_{sg}/2\pi = 6.83$  GHz for  $^{87}\text{Rb}$ )

$$g_{ac} = i \frac{\wp_{gs}}{\hbar} \epsilon_c u(\mathbf{r}) \sim 2\pi \times 20 \text{ Hz (magnetic dipole } \wp_{gs} \sim \mu_B/c = \frac{1}{2} \alpha a_0 e)$$

$$\Rightarrow \sqrt{N} g_{ac} \lesssim \kappa \text{ and } \sqrt{N} g_{ac} g_{qc} / \Delta_{qc} \lesssim \gamma_q$$

Large Decay & Decoherence

# State Transfer between SC & AE Qubits

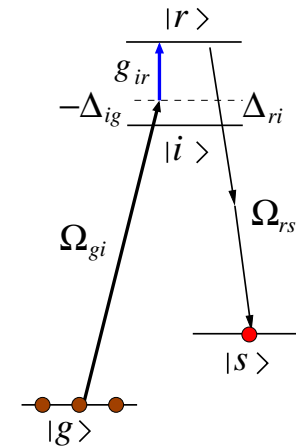
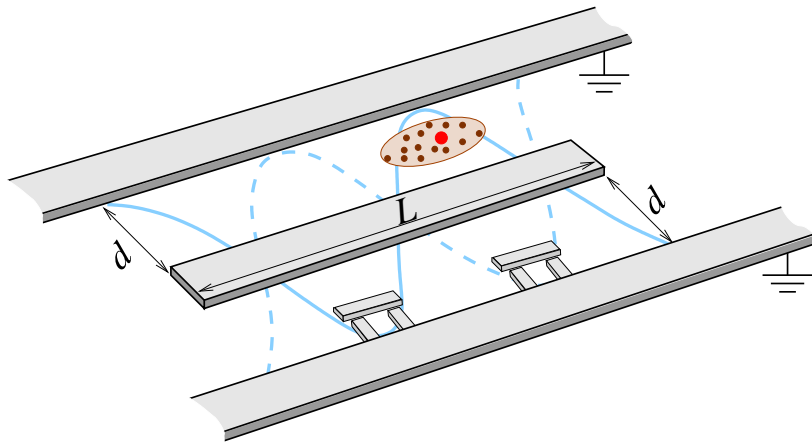

$|r\rangle, |i\rangle$  – Rydberg states with  $n \simeq 68$   $\omega_{ri} \simeq \omega_c \simeq 2\pi \times 12$  GHz

$g_{ir} = \frac{\wp_{ir}}{\hbar} \epsilon_c u(\mathbf{r}) \simeq 2\pi \times 4$  MHz atom–cavity coupling rate (el.-dip.  $\wp_{ir} \sim n^2 a_0 e \simeq 10^3 a_0 e$ )

$$\boxed{\Delta_{ri} = -\Delta_{ig} \gg g_{ir}, \sqrt{N}\Omega_{gi}} \quad g_{ir} \simeq \sqrt{N}\Omega_{gi} = \Delta/10$$

$\Rightarrow$  Two-photon Rabi frequency  $\Omega_{gr}^{(2)} = \frac{\sqrt{N}\Omega_{gi}g_{ir}}{\Delta_{ri}} \sim 0.1g_{ir}$

# State Transfer between SC & AE Qubits

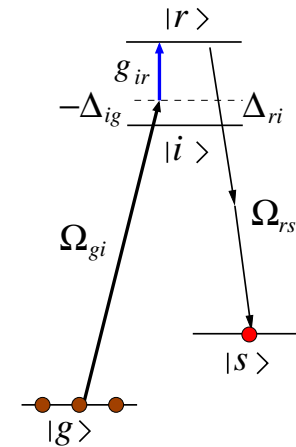
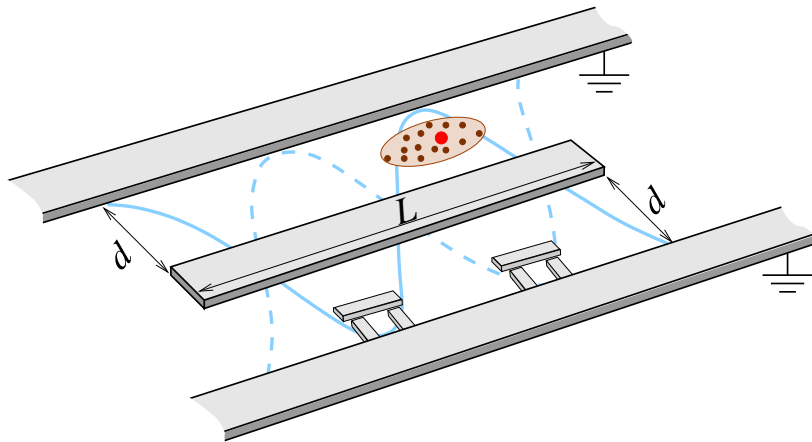

$|r\rangle, |i\rangle$  – Rydberg states with  $n \simeq 68$   $\omega_{ri} \simeq \omega_c \simeq 2\pi \times 12$  GHz

$g_{ir} = \frac{\wp_{ir}}{\hbar} \epsilon_c u(\mathbf{r}) \simeq 2\pi \times 4$  MHz atom–cavity coupling rate (el.-dip.  $\wp_{ir} \sim n^2 a_0 e \simeq 10^3 a_0 e$ )

$$\boxed{\Delta_{ri} = -\Delta_{ig} \gg g_{ir}, \sqrt{N}\Omega_{gi}} \quad g_{ir} \simeq \sqrt{N}\Omega_{gi} = \Delta/10$$

$\Rightarrow$  Two-photon Rabi frequency  $\Omega_{gr}^{(2)} = \frac{\sqrt{N}\Omega_{gi}g_{ir}}{\Delta_{ri}} \sim 0.1g_{ir}$

## Excitation Transfer from Cavity to Atoms

• Apply  $\Omega_{gi}$  ( $\pi$ -pulse:  $\Omega_{gr}^{(2)} T_{gr} = \frac{\pi}{2}$ )  $\Rightarrow$   $\boxed{|s^{(0)}\rangle |1_c\rangle \rightarrow |r^{(1)}\rangle |0_c\rangle}$

• Apply  $\Omega_{rs}$  ( $\pi$ -pulse:  $\Omega_{rs} T_{gr} = \frac{\pi}{2}$ )  $\Rightarrow$   $\boxed{|r^{(1)}\rangle \rightarrow |s^{(1)}\rangle}$

# Numerical Simulations

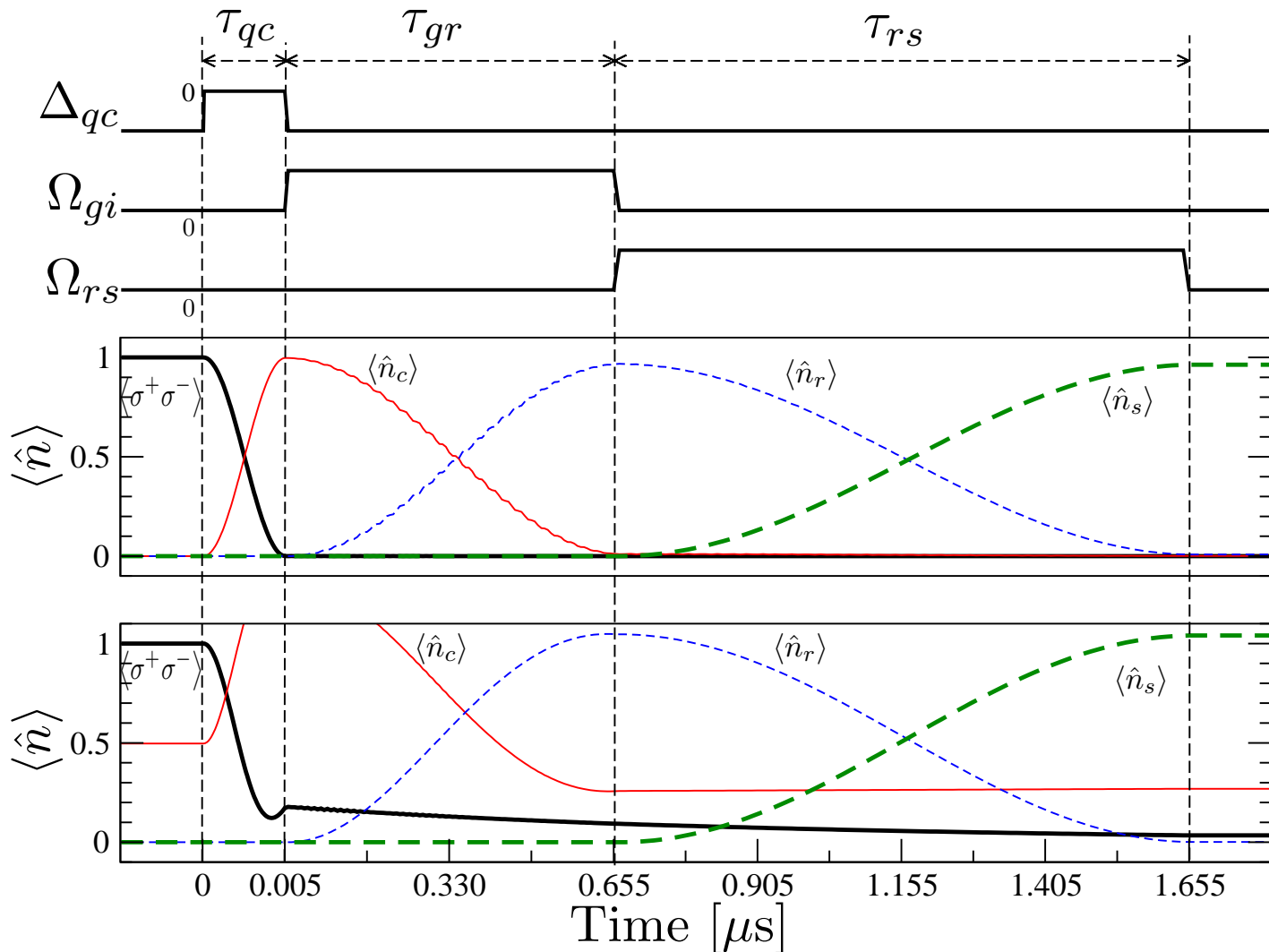

$$T = 0$$

$$[\langle \hat{n}_c \rangle = 0]$$

$$\frac{k_B T}{\hbar \omega_c} = 0.9$$

$$[\langle \hat{n}_c \rangle = 0.5]$$

$$|\Psi(0)\rangle = |1_q\rangle |s^{(0)}\rangle$$

$$\& \hat{\rho}_c = \frac{e^{-\hbar\omega\hat{n}_c/k_B T}}{\text{Tr}(e^{-\hbar\omega\hat{n}_c/k_B T})}$$

# Numerical Simulations

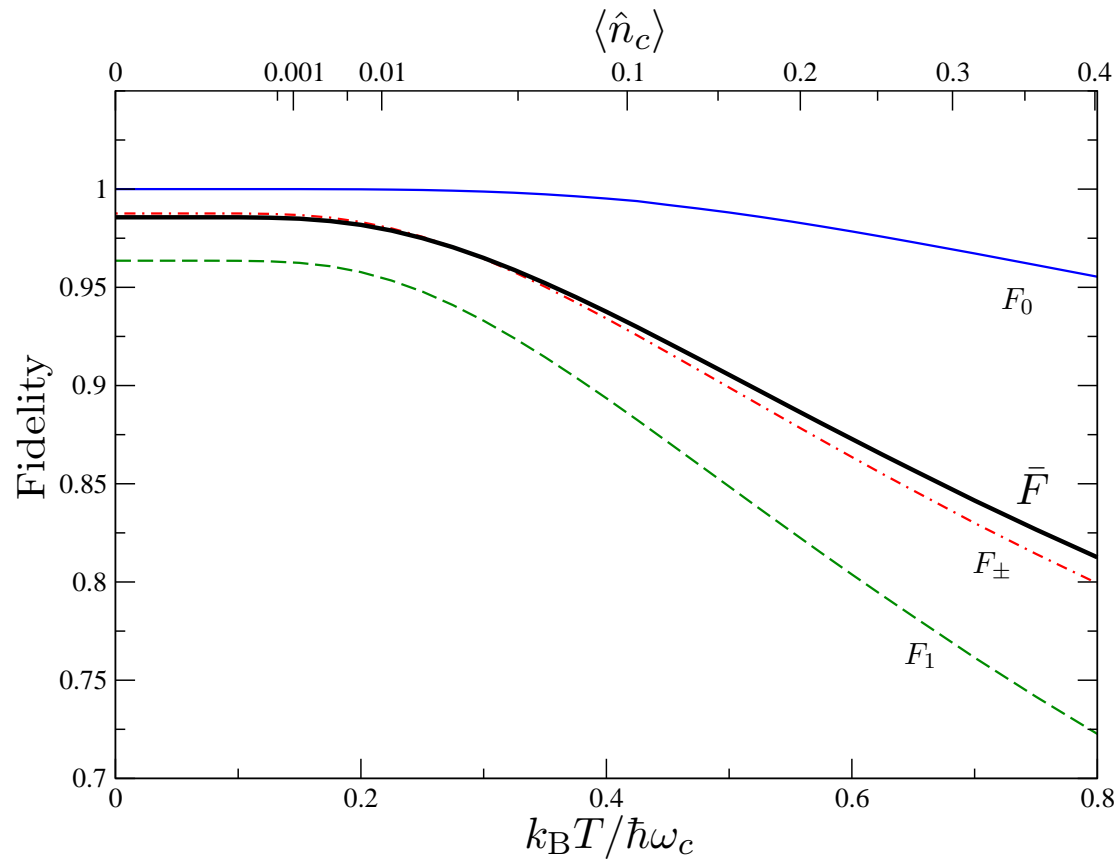

$$F_{\psi} = \text{Tr}(\hat{\rho} |\psi\rangle\langle\psi|)$$

$$\bar{F} = \frac{\int F_{\psi} d|\psi\rangle}{\int d|\psi\rangle}$$

$\bar{F} > 98\%$  for  $\frac{k_B T}{\hbar \omega_c} \leq 0.2$  [ $\langle \hat{n}_c \rangle = 0.01$ ]  $\Rightarrow T_{\text{crit}} = 0.1\text{K}$

# Atoms in CPW Resonator



Ensembles of cold ground-state atoms trapped near field antinodes

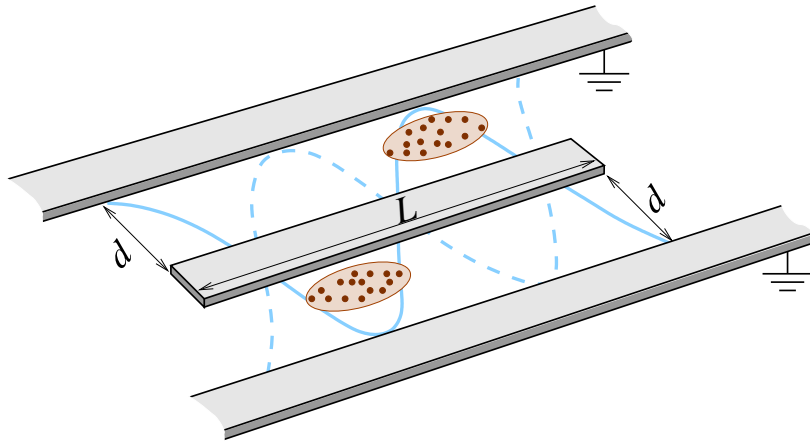

$$N = \rho_a V_a \sim 10^6 \text{ atoms in each ensemble}$$

# Atoms in CPW Resonator

Excited Rydberg atoms  $i$  &  $j$  interact via common cavity mode

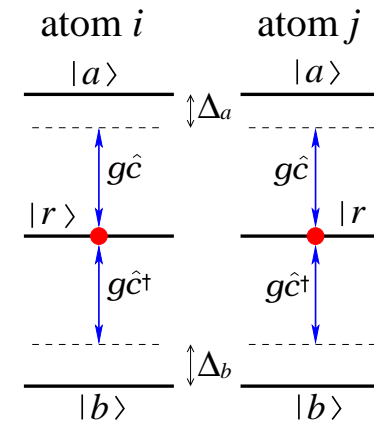
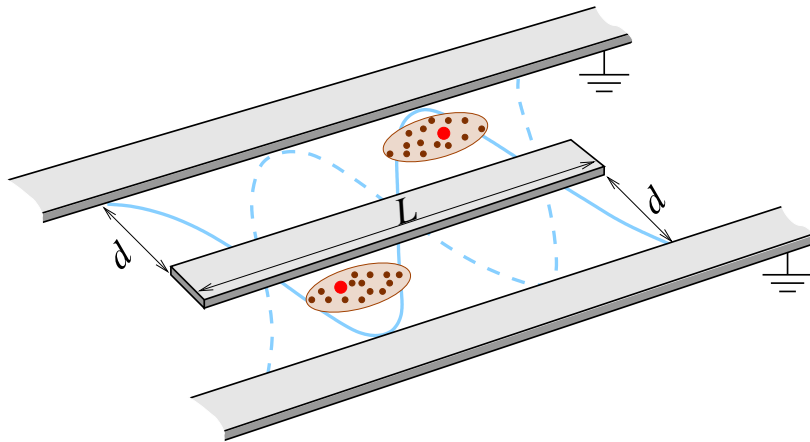

Hamiltonian for atom  $i$  + atom  $j$  + cavity field:

$$H = \hbar \sum_{l=i,j} [(\Delta_a \hat{\sigma}_{aa}^l - \Delta_b \hat{\sigma}_{bb}^l) + (g_{br}^l \hat{c}^\dagger \hat{\sigma}_{br}^l + g_{ar}^l \hat{c} \hat{\sigma}_{ar}^l + \text{H.c.})]$$

$\Delta_a = \omega_{ar} - \omega_c$  and  $\Delta_b = \omega_{rb} - \omega_c$  detunings

$\hat{\sigma}_{\mu\nu}^l = |\mu_l\rangle\langle\nu_l|$  atomic transition operator  $\hat{c}, \hat{c}^\dagger$  cavity field operators

$g_{\mu\nu}^l = -\frac{\wp_{\mu\nu}}{\hbar} \varepsilon_c u(\mathbf{r}_l)$  atom-field coupling ( $g_{br}^l \approx g_{ar}^l \equiv g_r \sim 2\pi \times 10$  MHz)

# Resonant Dipole-Dipole Interaction



$$\Delta_{a,b} \simeq g_r f \gg g_r \quad (f \gg 1)$$

- $|r_i\rangle |r_j\rangle |0_c\rangle \rightarrow |r_{i,j}\rangle |b_{j,i}\rangle |1_c\rangle$  (1Ph) nonresonant
- $|r_i\rangle |r_j\rangle |0_c\rangle \rightarrow |a_{i,j}\rangle |b_{j,i}\rangle |0_c\rangle$  (2Ph) **resonant**  
 (ac Stark compensated:  $\Delta_a - \Delta_b + s_a^{i,j} - s_r^i - s_r^j = 0$ )

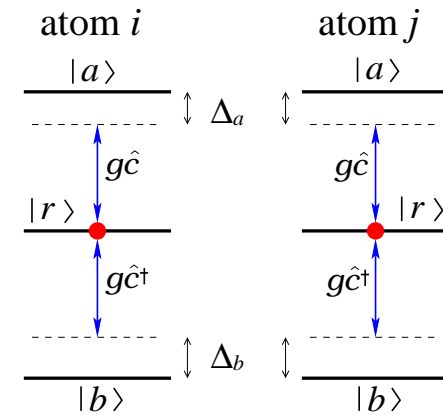

# Resonant Dipole-Dipole Interaction



Effective cavity-mediated RDDI  
between atoms  $i$  and  $j$

**Effective Hamiltonian** (2nd-order in  $g_r$ ):

$$V_{ij}^{(2)} = \hbar D_{ij} (\hat{\sigma}_{br}^i \hat{\sigma}_{ar}^j + \hat{\sigma}_{ar}^i \hat{\sigma}_{br}^j) + \text{H.c}$$

$$D_{ij} = \frac{g_{br}^i g_{ar}^j}{\Delta_b} = \frac{g_{ar}^i g_{br}^j}{\Delta_b} = \frac{g_r}{f} \equiv D \text{ — RDDI constant}$$

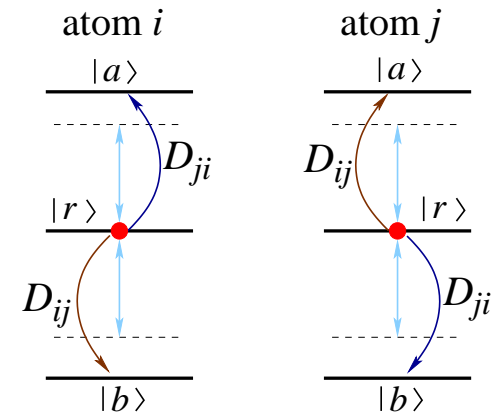

# Resonant Dipole-Dipole Interaction



Effective cavity-mediated RDDI  
between atoms  $i$  and  $j$

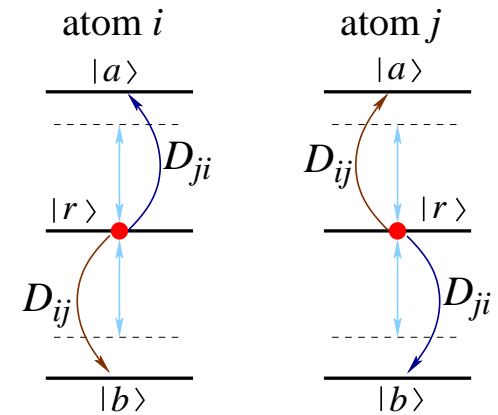

**Effective Hamiltonian** (2nd-order in  $g_r$ ):

$$V_{ij}^{(2)} = \hbar D_{ij} (\hat{\sigma}_{br}^i \hat{\sigma}_{ar}^j + \hat{\sigma}_{ar}^i \hat{\sigma}_{br}^j) + \text{H.c}$$

$$D_{ij} = \frac{g_{br}^i g_{ar}^j}{\Delta_b} = \frac{g_{ar}^i g_{br}^j}{\Delta_b} = \frac{g_r}{f} \equiv D \text{ — RDDI constant}$$

**Eigenstates of  $V_{ij}^{(2)}$**

$$|\psi_{ij}^0\rangle = \frac{1}{\sqrt{2}} (|b_i\rangle |a_j\rangle - |a_i\rangle |b_j\rangle) \quad \lambda_0 = 0$$

$$|\psi_{ij}^\pm\rangle = \frac{1}{\sqrt{2}} |r_i\rangle |r_j\rangle \pm \frac{1}{2} (|b_i\rangle |a_j\rangle + |a_i\rangle |b_j\rangle) \quad \lambda_\pm = \pm \hbar \sqrt{2} D_{ij}$$

# Van der Waals Interaction

$$\Delta_a \simeq g_r(f - 1) \quad \& \quad \Delta_b \simeq g_r f \quad (f \gg 1)$$

- 1ph and 2ph transitions nonresonant

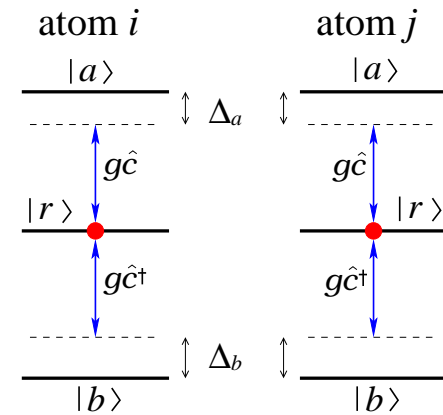

# Van der Waals Interaction

Effective cavity-mediated VdWI  
between atoms  $i$  and  $j$

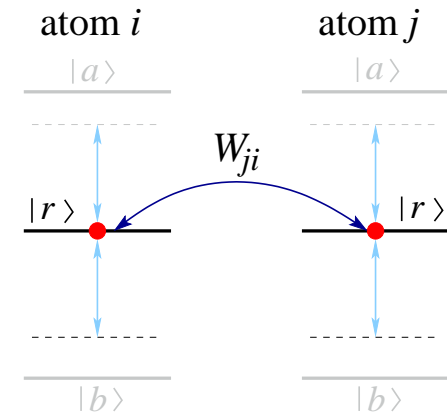

**Effective Hamiltonian** (4th-order in  $g_r$ ):

$$V_{ij}^{(4)} = \hbar \hat{\sigma}_{rr}^i W_{ij} \hat{\sigma}_{rr}^j$$

$$W_{ij} = \frac{2|g_{br}^i g_{br}^j|^2}{\Delta_b^3} - \frac{2|g_{br}^i g_{ar}^j|^2}{(\Delta_a - \Delta_b)\Delta_b^2} = \frac{4g_r}{f^3} \equiv W \text{ — WdVI constant}$$

# Van der Waals Interaction

Effective cavity-mediated VdWI  
between atoms  $i$  and  $j$

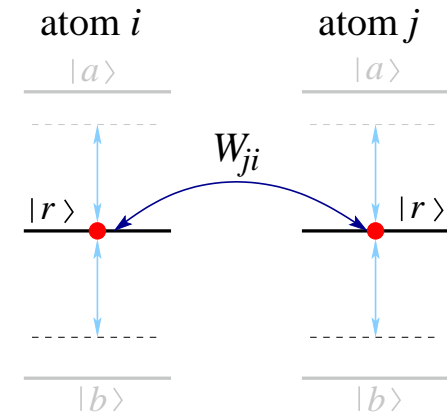

**Effective Hamiltonian** (4th-order in  $g_r$ ):

$$V_{ij}^{(4)} = \hbar \hat{\sigma}_{rr}^i W_{ij} \hat{\sigma}_{rr}^j$$

$$W_{ij} = \frac{2|g_{br}^i g_{br}^j|^2}{\Delta_b^3} - \frac{2|g_{br}^i g_{ar}^j|^2}{(\Delta_a - \Delta_b)\Delta_b^2} = \frac{4g_r}{f^3} \equiv W \text{ — WdVI constant}$$

**Evolution due to**  $V_{ij}^{(4)}$

$$|r_i\rangle |r_j\rangle \rightarrow e^{i\phi_{rr}(t)} |r_i\rangle |r_j\rangle \quad \phi_{rr}(t) = Wt$$

# Numerical Simulations



Dynamics of Rydberg atoms  $i, j$  in CPW cavity,  $|\Phi(0)\rangle = |r_i\rangle |r_j\rangle |0_c\rangle$

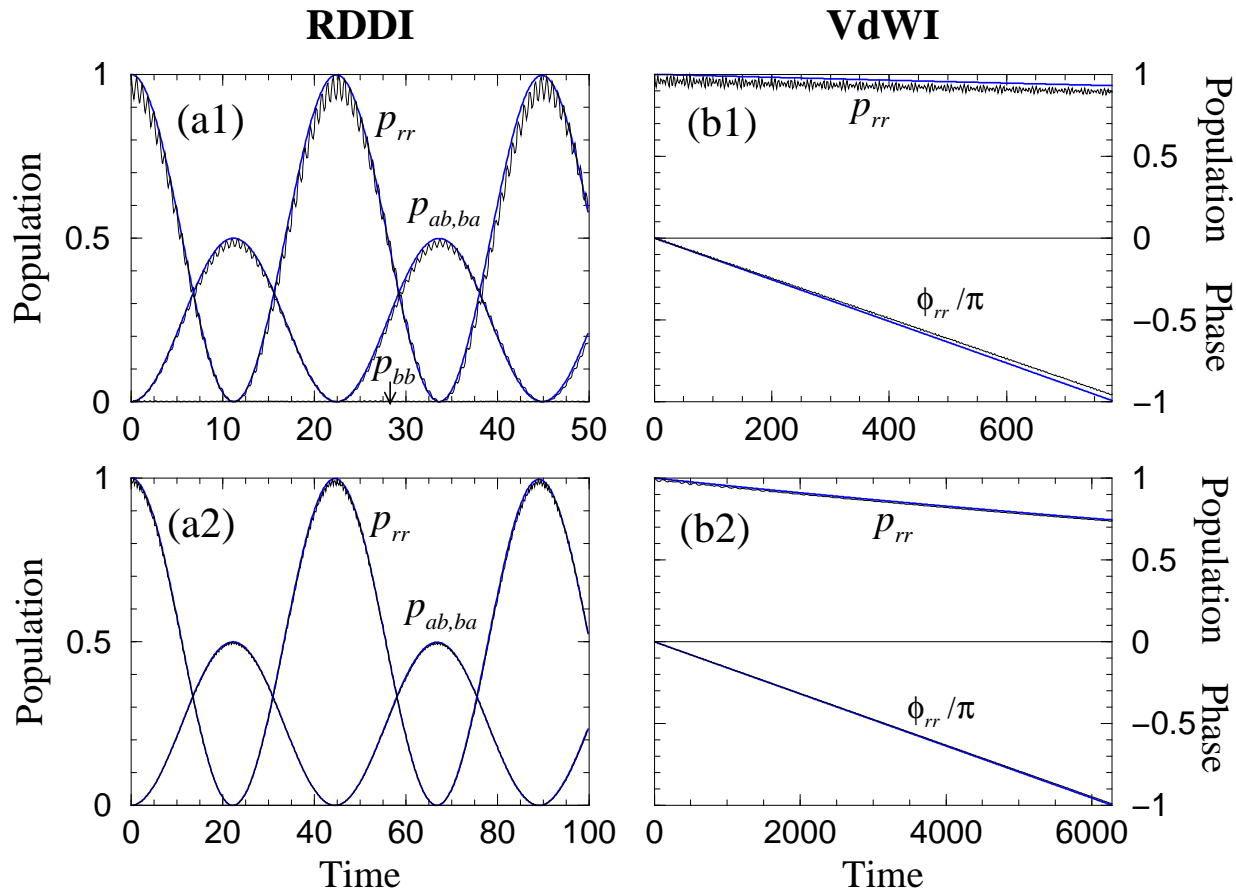

(a1),(b1)  $f = 10$

(a2),(b2)  $f = 20$

$p_{\mu\nu}$  populations of  $|\mu_i\rangle |\nu_j\rangle$      $\phi_{rr}$  phase-shift of  $|r_i\rangle |r_j\rangle$

“—”: ME simulations for the full system using Hamiltonian  $H$

“—”: ME simulations for the effective Hamiltonians  $V_{ij}^{(2)}$  and  $V_{ij}^{(4)}$

# Applications of RDDI



## Intracavity Dipole Blockade [ $D \simeq 2\pi \times 1 \text{ MHz}$ ( $f = 10$ )]

$$\langle rg | \hat{\sigma}_{gr} \Omega_{gr} | \psi^0 \rangle = 0 \ \& \ \Omega_{gr} < D \Rightarrow$$

Single Rydberg excitation of atomic ensemble by  $\Omega_{gr}$

(effective  $\pi$ -pulse:  $\sqrt{N} \Omega_{gr} T_1 = \frac{\pi}{2}$ )

$$\boxed{|s^{(0)}\rangle \rightarrow |r^{(1)}\rangle}$$

$$|s^{(0)}\rangle \equiv |g_1, g_2, \dots, g_N\rangle \quad |r^{(1)}\rangle \equiv \frac{1}{\sqrt{N}} \sum_i e^{i\mathbf{k}_{gr} \cdot \mathbf{r}_i} |g_1, \dots, r_i, \dots, g_N\rangle$$

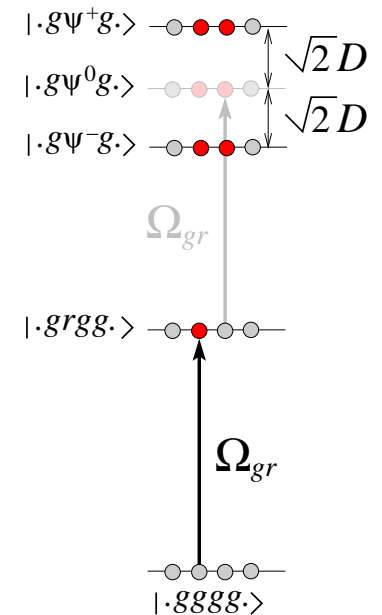

# Applications of RDDI

## Intracavity Dipole Blockade [ $D \simeq 2\pi \times 1 \text{ MHz}$ ( $f = 10$ )]

$$\langle rg | \hat{\sigma}_{gr} \Omega_{gr} | \psi^0 \rangle = 0 \ \& \ \Omega_{gr} < D \ \Rightarrow$$

Single Rydberg excitation of atomic ensemble by  $\Omega_{gr}$

(effective  $\pi$ -pulse:  $\sqrt{N} \Omega_{gr} T_1 = \frac{\pi}{2}$ )

$$\boxed{|s^{(0)}\rangle \rightarrow |r^{(1)}\rangle}$$

$$|s^{(0)}\rangle \equiv |g_1, g_2, \dots, g_N\rangle \quad |r^{(1)}\rangle \equiv \frac{1}{\sqrt{N}} \sum_i e^{i\mathbf{k}_{gr} \cdot \mathbf{r}_i} |g_1, \dots, r_i, \dots, g_N\rangle$$

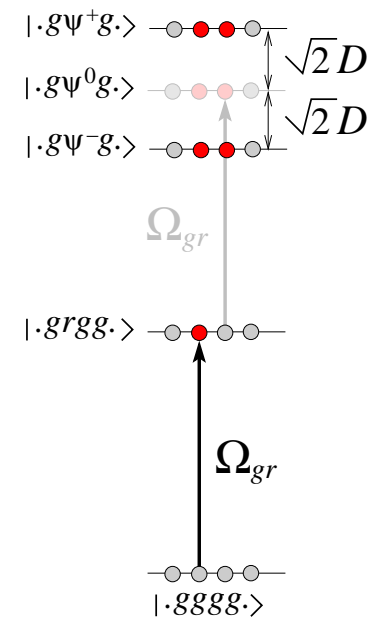

## Single Photon Generation

- Apply  $\Omega_{sr}$  ( $\pi$ -pulse:  $\Omega_{sr} T_2 = \frac{\pi}{2}$ )

$$|r^{(1)}\rangle \rightarrow |s^{(1)}\rangle$$

$$|s^{(1)}\rangle \equiv \frac{1}{\sqrt{N}} \sum_i e^{i\delta\mathbf{k} \cdot \mathbf{r}_i} |g_1, \dots, s_i, \dots, g_N\rangle$$

single collective Raman excitation of atomic ensemble  
(equivalent to EIT stored single photon)

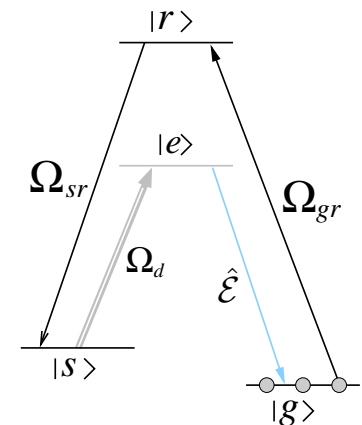

- Turn on  $\Omega_d \rightarrow$  release single photon pulse  $\hat{\mathcal{E}}$

# Applications of RDDI

## Intracavity Dipole Blockade [ $D \simeq 2\pi \times 1 \text{ MHz}$ ( $f = 10$ )]

$$\langle rg | \hat{\sigma}_{gr} \Omega_{gr} | \psi^0 \rangle = 0 \ \& \ \Omega_{gr} < D \Rightarrow$$

Single Rydberg excitation of atomic ensemble by  $\Omega_{gr}$

(effective  $\pi$ -pulse:  $\sqrt{N} \Omega_{gr} T_1 = \frac{\pi}{2}$ )

$$\boxed{|s^{(0)}\rangle \rightarrow |r^{(1)}\rangle}$$

$$|s^{(0)}\rangle \equiv |g_1, g_2, \dots, g_N\rangle \quad |r^{(1)}\rangle \equiv \frac{1}{\sqrt{N}} \sum_i e^{i\mathbf{k}_{gr} \cdot \mathbf{r}_i} |g_1, \dots, r_i, \dots, g_N\rangle$$

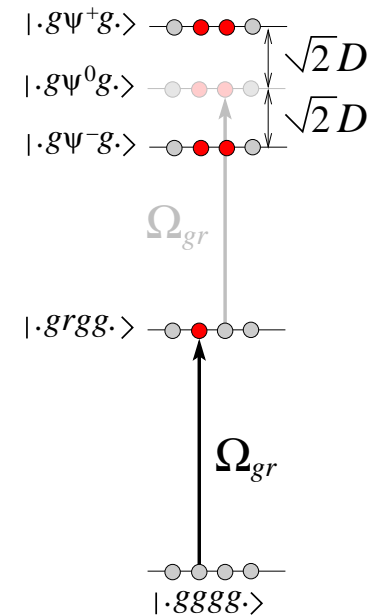

## Entangling two (or more) ensembles $A$ and $B$

- Apply  $\Omega_{gr}$  simultaneously to  $A$  and  $B$  ( $\sqrt{2N} \Omega_{gr} T_1 = \frac{\pi}{2}$ )

- Apply  $\Omega_{sr}$  ( $\pi$ -pulse:  $\Omega_{sr} T_2 = \frac{\pi}{2}$ )

$$\Rightarrow \frac{1}{\sqrt{2}} ( |s^{(1)}\rangle_A |s^{(0)}\rangle_B + |s^{(0)}\rangle_A |s^{(1)}\rangle_B )$$

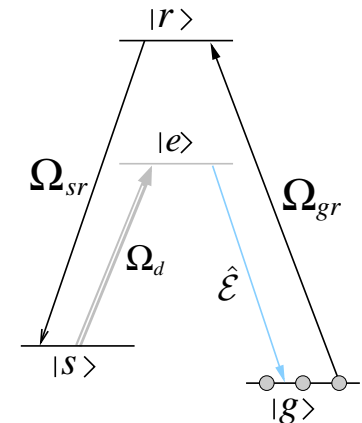

# Applications of VdWI

---



**Dispersive phase shift** [ $W \simeq 2\pi \times 40$  KHz ( $f = 10$ )]

$$|r\rangle |r\rangle \rightarrow e^{i\phi(t)} |r\rangle |r\rangle \quad \phi(t) = Wt$$

# Applications of VdWI

**Dispersive phase shift** [ $W \simeq 2\pi \times 40$  KHz ( $f = 10$ )]

$$|r\rangle |r\rangle \rightarrow e^{i\phi(t)} |r\rangle |r\rangle \quad \phi(t) = Wt$$

Ensemble qubits  $A, B, \dots$  in states

$$|\psi\rangle_q = \alpha_q |s^{(0)}\rangle_q + \beta_q |s^{(1)}\rangle_q$$

- Apply  $\Omega_{sr}$  to  $A$  &  $B$  ( $\Omega_{sr}T_1 = \frac{\pi}{2}$ ):

$$|s^{(1)}\rangle_{A,B} \rightarrow |r^{(1)}\rangle_{A,B}$$

- Phase-shift  $\phi = WT_\pi = \pi$  (during  $T_\pi = \pi/W$ )

- Apply  $\Omega_{sr}$  again ( $\Omega_{sr}T_2 = \frac{\pi}{2}$ ):

$$|r^{(1)}\rangle_{A,B} \rightarrow |s^{(1)}\rangle_{A,B}$$

$\Rightarrow$  **Universal CPHASE gate between ensemble qubits  $A$  &  $B$**

$$|s^{(x)}\rangle_A |s^{(y)}\rangle_B \rightarrow (-1)^{xy} |s^{(x)}\rangle_A |s^{(y)}\rangle_B \quad (x, y \in [0, 1])$$

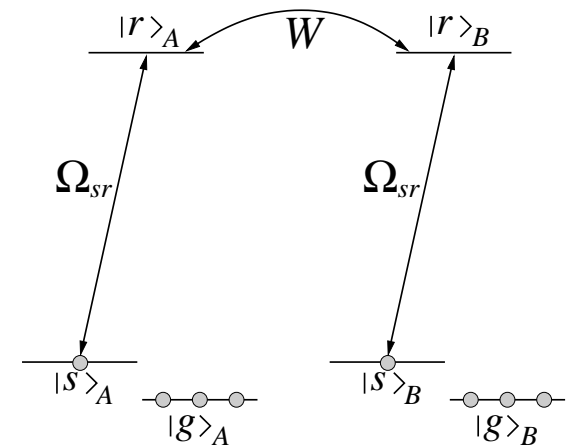

# Applications of VdWI

**Dispersive phase shift** [ $W \simeq 2\pi \times 40$  KHz ( $f = 10$ )]

$$|r\rangle |r\rangle \rightarrow e^{i\phi(t)} |r\rangle |r\rangle \quad \phi(t) = Wt$$

Photonic qubits  $A, B, \dots$  in states

$$|\psi\rangle_q = \alpha_q |0\rangle_q + \beta_q |1\rangle_q$$

- EIT dark-state polaritons in ensembles  $A$  &  $B$

$$\Psi_{A,B} = \cos \theta \hat{\mathcal{E}}_{A,B} - \sin \theta \sqrt{N} \hat{\sigma}_{gr}^{A,B}$$

- Phase shift  $\phi = WT_{\text{int}} = \pi$  ( $T_{\text{int}} = \frac{L_a}{v_g}$ ,  $v_g = c \cos^2 \theta \ll c$ )

$\Rightarrow$  **Universal CPHASE gate between photonic qubits  $A$  &  $B$**

$$|x\rangle_A |y\rangle_B \rightarrow (-1)^{xy} |x\rangle_A |y\rangle_B \quad (x, y \in [0, 1])$$

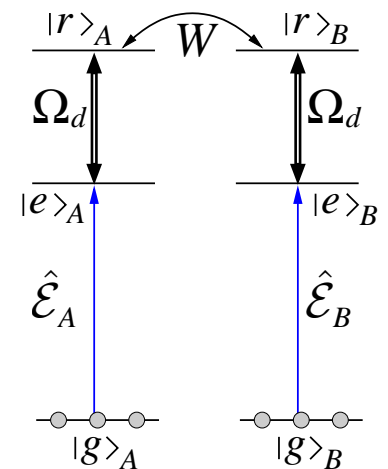

# Conclusions: Efficient QI Processing

---



- **Elements of Quantum Processor**
  - solid state SC qubits – fast quantum gates
  - metastable states of cold atoms – reliable quantum memory
  - single photons – long-distance information transfer

# Conclusions: Efficient QI Processing



## ● Elements of Quantum Processor

- solid state SC qubits – fast quantum gates
- metastable states of cold atoms – reliable quantum memory
- single photons – long-distance information transfer

## ● Interactions & Interface between Qubits

- EIT provides interface between static (AE) and flying (SPh) qubits
- Microwave CPW resonators
  - *serve as quantum bus for SC and AE qubits*
  - *mediate RDDI and VdWI between atoms over  $L \sim 1$  cm*
    - single photon generation
    - quantum gates between AE and SPh qubits

## ● Elements of Quantum Processor

- solid state SC qubits – fast quantum gates
- metastable states of cold atoms – reliable quantum memory
- single photons – long-distance information transfer

## ● Interactions & Interface between Qubits

- EIT provides interface between static (AE) and flying (SPh) qubits
- Microwave CPW resonators
  - serve as quantum bus for SC and AE qubits
  - mediate RDDI and VdWI between atoms over  $L \sim 1$  cm
    - single photon generation
    - quantum gates between AE and SPh qubits

## ● Experimental efforts

- SC qubits in CPW resonators (Yale, NIST-Boulder, ETH Zürich ...)
- CPW, SC qubits & trapped AE on atom chip (MIDAS: TU-Wien, WIS ...)
- Free-space Rydberg blockade via DDI [ $r_{ij}^{-3}$ ] and VdWI [ $r_{ij}^{-6}$ ]
- EIT in warm & cold AEs, OLs [ $1/\gamma_{sg} \gtrsim 1$  s], doped solids ...

# Acknowledgements

---



## Collaborators

Michael Fleischhauer  
TU Kaiserslautern

Guy Bensky  
Gershon Kurizki  
Weizmann Inst.

Igor Mazets  
Johannes Majer  
Jörg Schmiedmayer  
TU Wien

## Financial support



Macroscopic Interference Devices  
for Atomic and Solid-State Systems